

SIDEWALK DINING

Design Guidelines





Department of Community and Neighborhoods

Real Estate Services Division

451 South State Street - Room 425

P.O. Box 145460

Salt Lake City, UT 84114 - 5460

Contents

5	PURPOSE & GOALS OF DESIGN GUIDELINES
6	PERMITTING & APPLICATION PROCESS
9	APPLICATION MATERIALS
13	ACCEPTABLE TYPES OF SIDEWALK DINING
25	DESIGN GUIDELINES
46	GLOSSARY
45	REFERENCES
45	CONTACT US

Sidewalk dining guidance may change, please visit our website to ensure you have the most recent version of these guidelines.

<https://www.slc.gov/planning/zoning>

Version 3.0 | August 2021



Purpose & Goals of Design Guidelines

The purpose of this document is to facilitate the creation of sidewalk dining areas that enliven and enhance public life, and to assist establishment operators in creating safe, attractive, and inviting dining areas on or next to the sidewalk for patrons and pedestrians.

The goal of these design guidelines is to ensure that the design of sidewalk dining areas both meets Salt Lake City's objective of creating a dynamic, lively streetscape and supports an equitable pedestrian experience for people of all mobility levels.

People interacting and participating in city life are the reason for outdoor dining: the life on the sidewalk is the main attraction.

Salt Lake City has many competing demands for use of the public sidewalk; these design guidelines aim to balance the needs of pedestrians and businesses to ensure access, safety, comfort, and enjoyment for everyone.

The pedestrian walkway is the highest priority on the public sidewalk, and all sidewalk dining must preserve safe, comfortable, and accessible pedestrian pathways for all people on the sidewalk.

Sidewalk Dining Area:

A sidewalk dining area is an outdoor area located within the public right-of-way (ROW) which is operated and maintained by an establishment that serves food and/or beverages, such as coffeehouses, tea shops, bars, or restaurants.

Permitting & Application Process

Sidewalk dining is permitted through an administrative approval process led by the Salt Lake City's Department of Community and Neighborhoods Division of [Real Estate Services](#).

Application review is performed by the Encroachment Review Team, and consists of staff from the Departments of Community and Neighborhoods and Public Utilities.

After application review and sign-off, the Real Estate Services Division issues the final approval and permit for the sidewalk dining encroachment.

Fees and Costs

Sidewalk Dining Revocable Permit fees are assessed based on the square footage of the right-of-way area leased, and are due annually.

Sidewalk dining operators are required to provide commercial general liability insurance that meets or exceeds minimums set by Salt Lake City.

[Real Estate Services](#) maintains current information on square footage lease fees and required liability coverage amounts.

Eligibility

Applications for sidewalk dining areas that meet the requirements of these guidelines are eligible for approval.

Note: *There may be instances where City staff requires additional design interventions not covered in these guidelines.*

Sidewalk dining approval is ultimately subject to the discretion of the Salt Lake City Corporation.

Sidewalk and ROW Use

The design of the sidewalk dining area shall use positive action to assure that its use of the right-of-way (including the sidewalk, park strip, and parking stalls) in no way interferes with or limits sidewalk users' free and unobstructed passage.

Sidewalk Dining Application Process

● Applicant ● City Staff

STEP 1 // PREPARE



1. Review Sidewalk Dining Guidelines

Review these Guidelines to determine the most suitable location and type of outdoor dining area for your establishment.

2. Determine Eligibility

If you can answer yes to the following questions, your location may be eligible for sidewalk dining:

- Can I meet Salt Lake City's insurance requirements?
- Can I maintain the minimum *pedestrian clear zone* in my location?
- If my establishment serves alcohol, can I meet *DABC requirements*?

If there are other sidewalk dining areas on the same block face:

- Is my proposed dining area aligned with neighboring dining areas to create a *continuous pedestrian clear zone*?

STEP 2 // SUBMIT



3. Develop Preliminary Drawings

Develop a preliminary site plan, elevations, and photos/drawings of furniture and other materials used in the proposed sidewalk dining area.

4. Submit Application

Submit an *online encroachment application* with all required site plans, elevations, and photos/drawings of furniture and any other required materials.

For tables and chairs required to be removed daily, submit an **outdoor dining revocable permit** application.

For sidewalk dining areas with furnishing to remain during non-operating hours, submit a **commercial revocable permit** application.

STEP 3 // REVIEW



5. Application Assigned to Encroachment Review Team

Applications are pre-screened and routed to the encroachment review team (ERT). The team will review each application request based on location and design criteria.

After review each ERT member will make a recommendation of *acceptance, rejection, or additional information needed*.

7. Provide Revisions (as requested)

You may have requests for revision from one or more members of the ERT. Once you have satisfied all requests for revision, upload revised plans, elevations, or other materials.

8. Final Approval & Lease Agreement

Upon ERT approval, work with *Real Estate Services* for final approval of the sidewalk dining revocable permit, pay the invoice, and sign a lease agreement.

Sidewalk Dining Application Process

● Applicant ● City Staff

To apply for a revocable permit for sidewalk dining, please follow these steps in order:

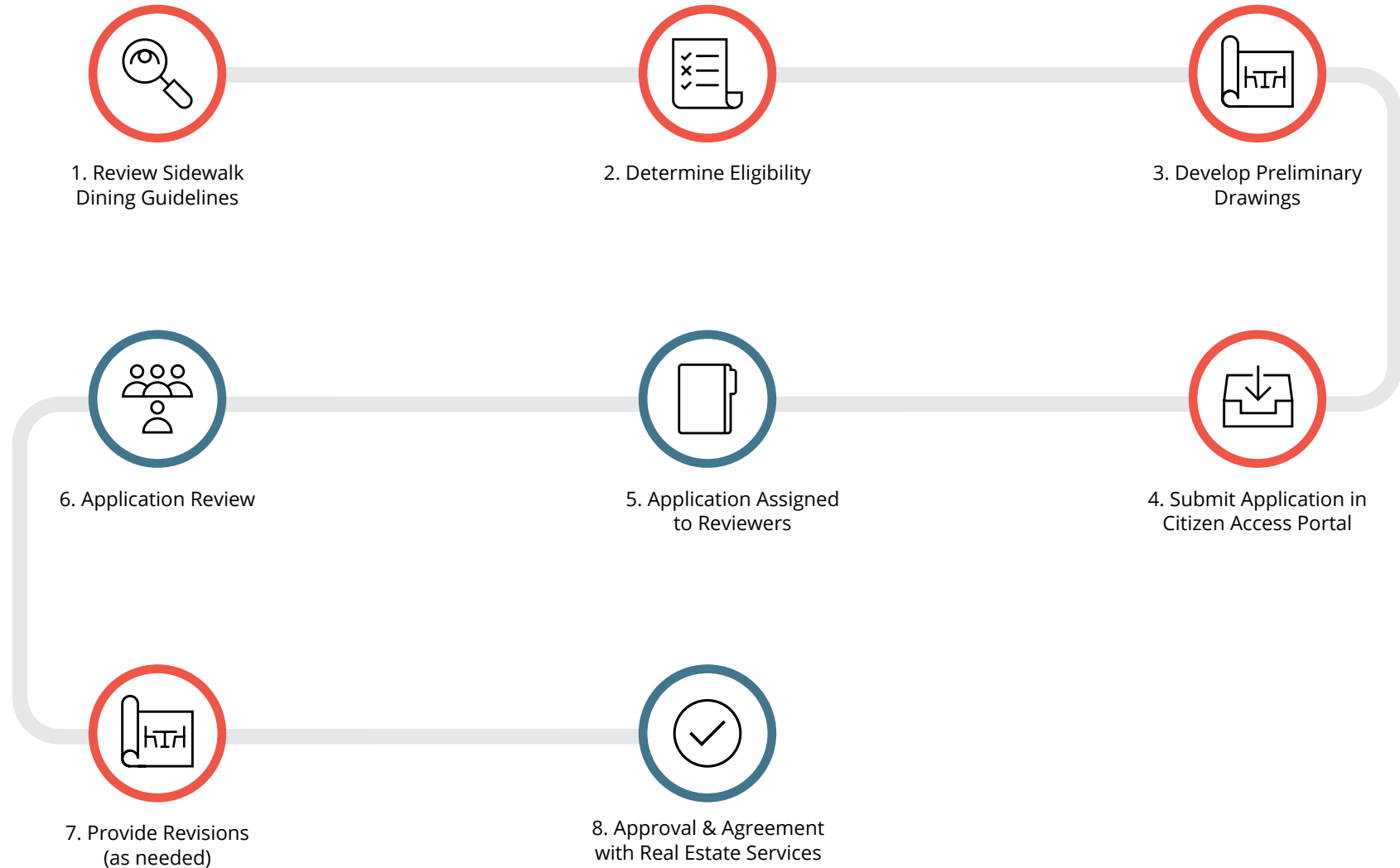

Application Materials

1. Written Statement

A brief statement that includes:

- the applicant’s name, address, and telephone number
- interest in the property (i.e. owner or establishment operator)
- name of the establishment
- a description of the proposed sidewalk dining area that includes:
 - * the square footage of the dining area,
 - * number of seats and tables, and
 - * percentage of accessible tables (See [Section 10: Furniture](#), for details).

2. Site Photographs

- Submit two current photos that clearly depict the proposed site for sidewalk dining. The photos should include:
 - * the building façade
 - * the curb
 - * any existing streetscape elements (see p. 10 for examples) in the sidewalk in front of the building.
- If present, include the park strip (the area between the sidewalk and the curb) in the photos.
- Photos should be taken from both sidewalk directions.

Note: Street view captures from Google Maps or similar are not acceptable.

SITE PHOTOGRAPH EXAMPLE (EAST FACING)



SITE PHOTOGRAPH EXAMPLE (WEST FACING)



Required Application Materials

3. Site Plan

Submit a site plan drawn to scale showing the proposed sidewalk dining space, and meeting all pedestrian clear zone requirements (*defined below*).

Plans should include:

1. A north arrow, scale, and date.
2. The names, addresses, and telephone numbers of the architect, landscape architect, planner or engineer on the project (*if applicable*).
3. The boundaries of the building associated with the sidewalk dining area, all property lines, all existing curb lines, and names of existing streets in or next to the project area.
4. The location and dimensions (*length and width*) of any other sidewalk dining areas immediately adjacent to the proposal.
5. The exact length and width of the proposed sidewalk dining area.
6. The location and size of all existing street furniture and other existing streetscape elements in and adjacent to the sidewalk dining area.

Streetscape Elements

Streetscape elements include, but are not limited to:

- * bus stops
- * fire hydrants and fire pipes
- * manhole covers or utility access
- * utility boxes and poles
- * parking meters
- * trees or tree grates
- * bicycle racks
- * signposts
- * posts (*e.g. bollards or parking stanchions*)
- * mailboxes or newspaper boxes
- * trash/recycling receptacles;
- * benches
- * other street furnishings

7. Clearly labeled dimensions between the sidewalk dining area and existing streetscape elements.
 - * Take measurements between trees and sidewalk dining areas from the edge of the tree grate closest to the proposed dining area.
8. The dimensions of the pathway between the establishment entry and the sidewalk dining area.
9. The location and dimensions of all proposed furniture, umbrellas/shade sails, lighting, barriers, and/or planters.
10. The location, dimensions, and material of any proposed signage.
11. The location and percentage of ADA accessible seating.

Note: The presence of underground utilities may increase the need to close sidewalk dining areas for maintenance or emergency access (See [Section 14: Removal](#), for details).

Underground utility locations are available upon request at PUDevServ@slcgov or 801-483-6727.

Pedestrian Clear Zone is Defined as:

The continuous, straight, unobstructed public sidewalk width dedicated to the path of travel (See [Section 1: Pedestrian Clear Zone](#), for details).

4. Elevation or Section(s) Drawing

Elevations or sections shall be drawn to scale and include dimensions of tables, chairs, umbrellas, planters, freestanding barriers, and any other elements included in the sidewalk dining area.

5. Photos or Drawings

Submit color photos, renderings, or graphics showing the type and material of furniture, umbrellas or shade sails, and/or planters. If barriers are required to meet design guidelines, submit color photos, renderings, or graphics for these too.

Note: Product brochures are acceptable.

6. Sidewalk Dining in Historic Districts

If the sidewalk dining area is located adjacent to a historic landmark site or within a historic preservation overlay district, the applicant is required to obtain a [Certificate of Appropriateness](#) from the Planning Division. For information on the location of landmark sites and local historic districts, see the [Salt Lake City Zoning Lookup Map](#).

7. Outdoor Dining on Private Property

These guidelines apply only to dining areas (or any portion thereof) located within the public right of way.

Outdoor dining areas (or any portion thereof) on private property are required to comply with Salt Lake City Code [Chapter 21A.40.065: Outdoor Dining](#).

Establishment operators should use all available private property to accommodate outdoor dining before requesting use of the public sidewalk.

8. Time to Process

The time to process applications depends on the completeness of the application, and the number of elements in the proposed sidewalk dining area.

In general, the fastest type of application to process and approve is a simple arrangement of tables and chairs made of durable materials.

Sidewalk dining within 5 feet of streetlights, manholes, hydrants, meters, grease traps, storm drain infrastructure, and other critical utility infrastructure may require additional review time and/or significant modification to the proposed design.

9. Changes to Application or Existing Sidewalk Dining Area

Any changes or additions to an approved application or existing sidewalk dining area shall require submission of a new application.

Note for Building Owners and Developers

Building owners who are interested in offering sidewalk dining areas as an amenity may apply for a sidewalk dining permit when an establishment operator has been identified, and not before.

In the building design or renovation phase, the Planning Division recommends creative ways to maximize indoor/outdoor threshold space on the property, rather than leasing public space.

(See [Section 1.7: Narrow Sidewalks and New Buildings](#), and [Figures 1.8, and 1.9](#), for details).



ACCEPTABLE TYPES OF SIDEWALK DINING

- 14 FRONTAGE
- 15 SINGLE-TABLE
- 16 SIDE WALL
- 17 CURBSIDE
- 19 PARKLET

Frontage

Frontage dining areas are located directly in front of the building façade.

This type of sidewalk dining area is suitable where the following conditions exist:

- Generous sidewalks (typically greater than 15 feet wide, most often found Downtown).
- Ability to maintain required pedestrian clear zone (See [Section 1: Pedestrian Clear Zone](#), for details).

FRONTAGE DINING AREA

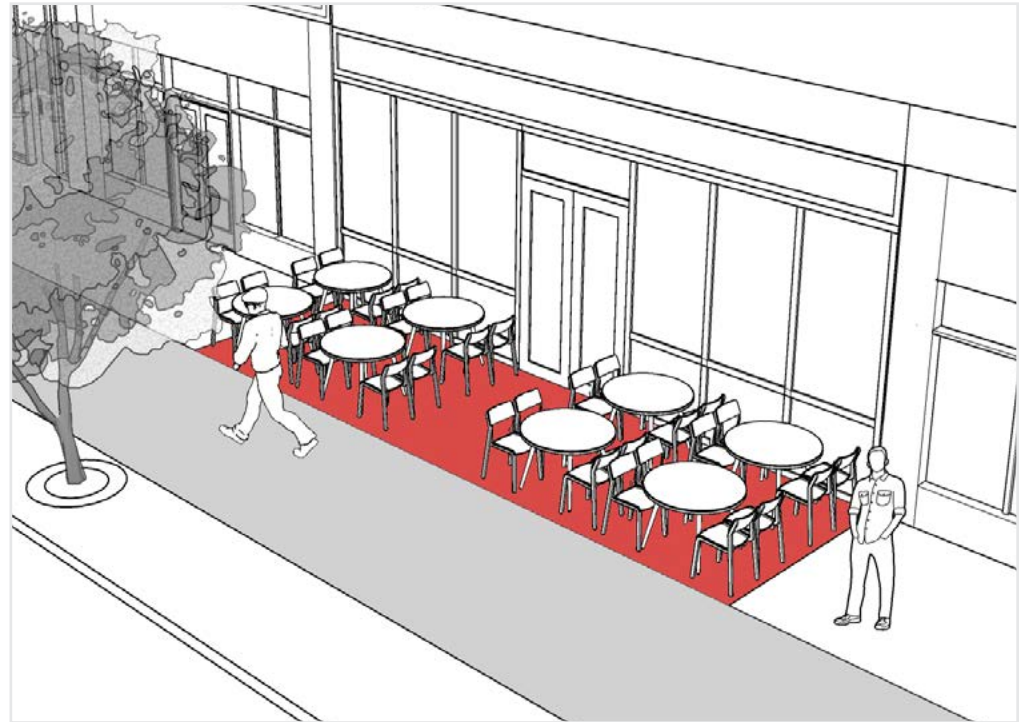

■ Dining Area ■ Pedestrian Clear Zone

Single-Table

Single-table dining areas occupy the area directly adjacent to the building front or side wall façade, and can be effective in many locations.

These are often suitable where some or all of the following conditions exist:

- Medium-sized sidewalks (typically between 10 and 12 feet wide).
- Building frontage has a small setback from the sidewalk.
- Constrained pedestrian clear zone.

SINGLE-TABLE DINING AREA

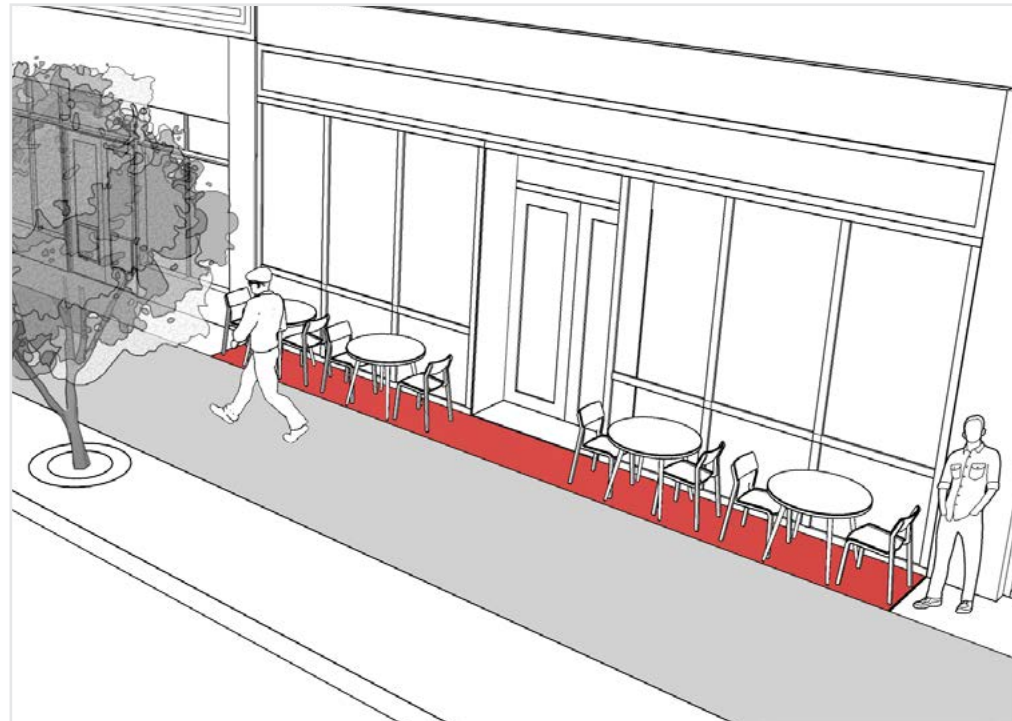

■ Dining Area ■ Pedestrian Clear Zone

Side Wall

Side wall dining areas are located on corner lots along the secondary façade of a building.

These are often suitable where some or all of the following conditions exist:

- Sidewalks are generous (typically greater than 12 feet wide)
- The building's side wall façade has doors onto the sidewalk.
- The building has doors on the corner where the primary and side façade meet.

SIDE WALL DINING AREA

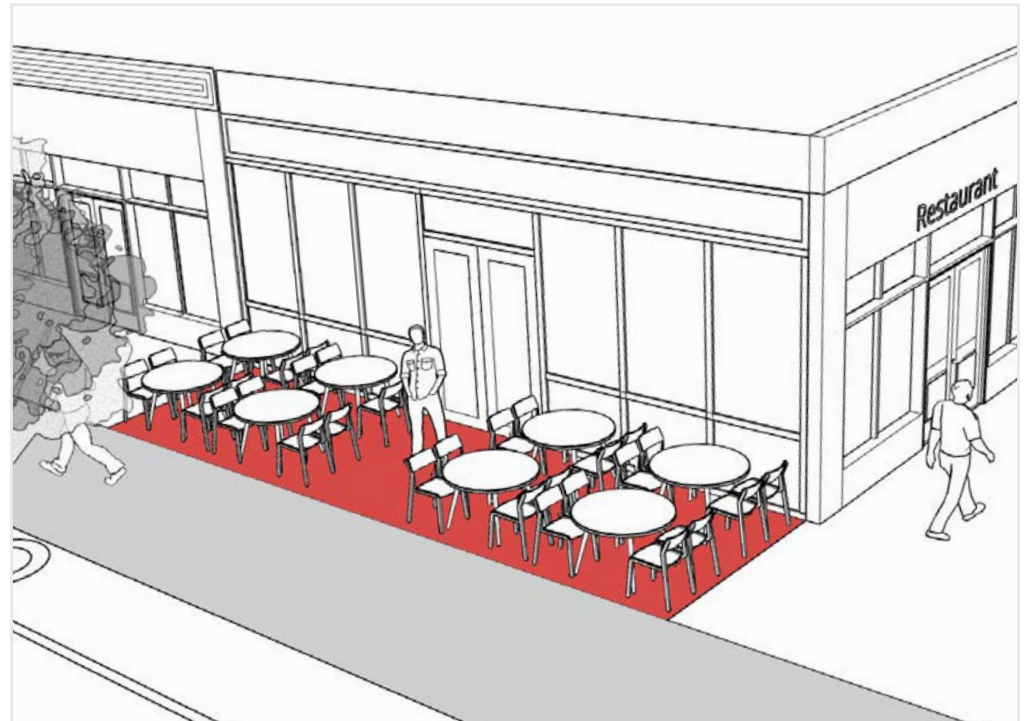

■ Dining Area ■ Pedestrian Clear Zone

Curbside

Curbside dining areas are located adjacent to the curb, and are separated from the building façade by the pedestrian clear zone.

Curbside Dining Areas have additional requirements to those located next to building façades:

- Curbside dining areas are prohibited next to ADA access areas or on-street ADA parking spaces.
- Curbside areas shall maintain all furniture and/or barriers at a distance of at least 18 inches from the back of curb.
- Curbside dining areas within existing park strips shall comply with all park strip landscaping standards. (See [Chapter 21A.48.060 of the Salt Lake City Code](#), for additional information on park strip requirements).

CURBSIDE DINING AREA

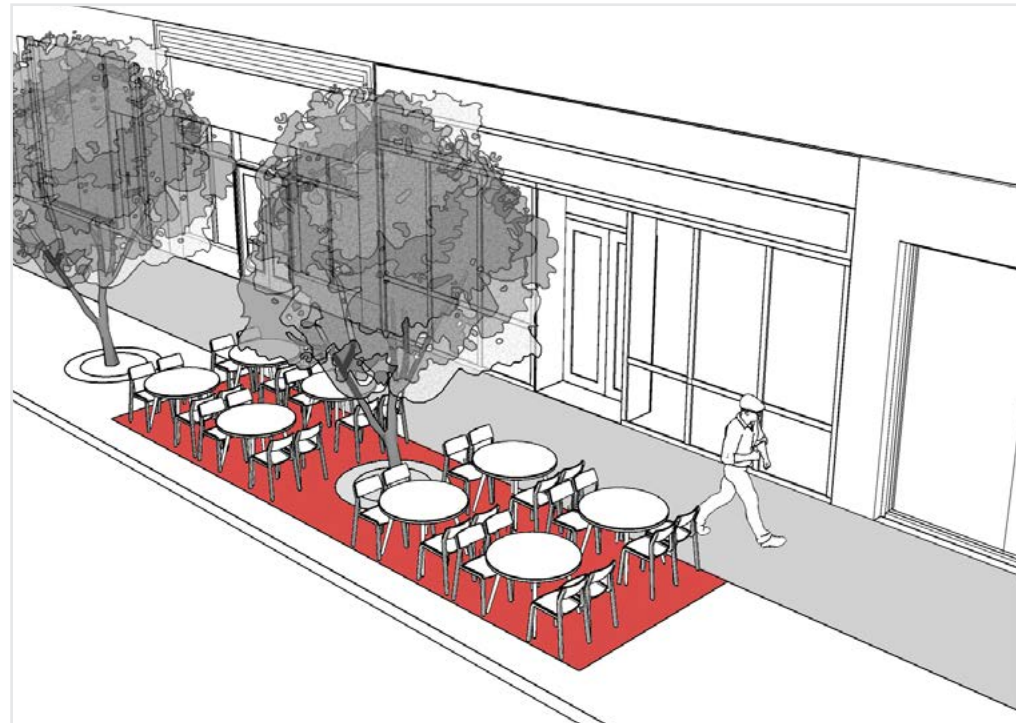

■ Dining Area ■ Pedestrian Clear Zone

Curbside Trees

City-owned trees are public infrastructure that improve air and water quality and contribute to the image of Salt Lake City.

For curbside dining areas located within park strips where trees (or potential tree planting locations) exist, the applicant shall obtain approval from [Salt Lake City's Urban Forestry Division](#) to ensure dining areas will not conflict with plans for tree planting and/or maintenance.

Poured concrete shall not be placed in any park strip with existing street trees with limited exceptions. (See [Section 21A.48.060 E 5a: Paving Materials Near Existing Street Trees](#), for details.)

It is the applicants responsibility to maintain adequate soil volume and irrigation to grow healthy trees in the park strip using methods recommended by the Urban Forestry Division.

These methods may include a combination of:

- structural soils.
- soil cell pavement support systems.
- pervious paving.
- bubbler irrigation.
- smart irrigation controllers.
- other soil volume or irrigation systems not listed here.

CURBSIDE DINING AREA WITH TREES



Parklet

Parklets are mini-parks, created by replacing 1 or more on-street parking stalls with a deck, planters, café tables, chairs, benches, and artwork.

The Salt Lake City Planning Division encourages the use of parklet dining areas to enhance the public realm and provide a more generous pedestrian zone with fewer obstructions on the sidewalk.

By creating a dining area in a parklet, establishments can add approximately 200 to 600 square feet of space for outdoor dining.

Despite their small size, parklets can pose complex design and durability challenges.

Note: *The Salt Lake City Planning Division strongly recommends that establishment operators work with a licensed professional designer, such as an architect or landscape architect, to reduce permit processing time and parklet maintenance costs through higher quality design, materials, and project execution.*

Note to Business Owners and Developers:

Salt Lake City's Department of Economic Development can provide loans for the design and construction of parklet dining areas through the [Economic Development Loan Fund \(ELDF\)](#).

PARKLET DINING AREA

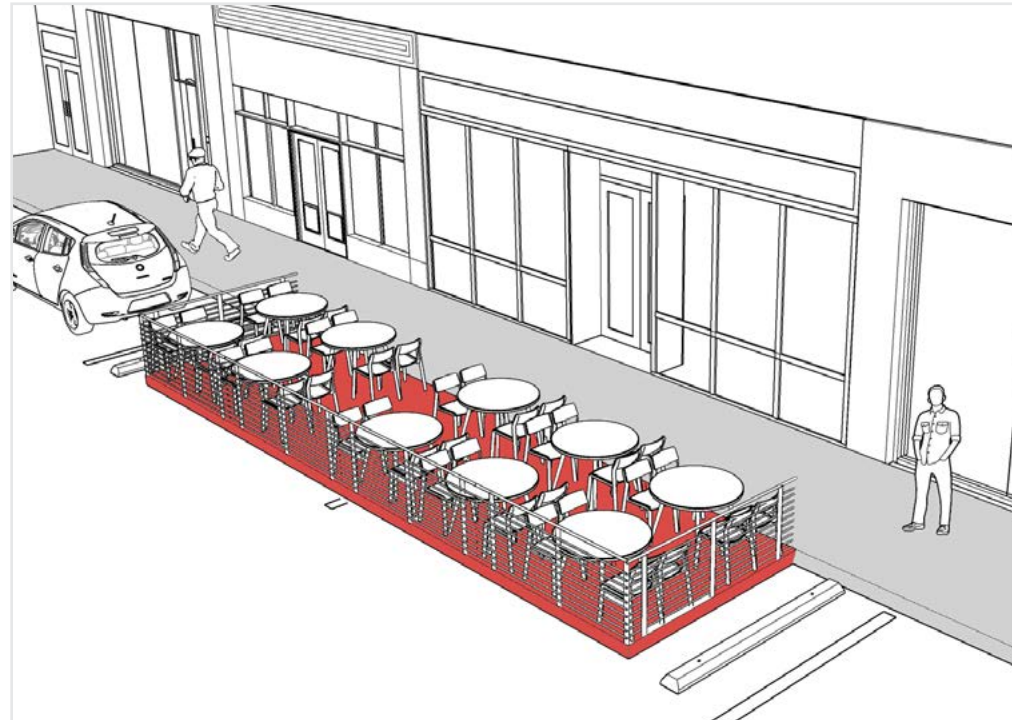

■ Dining Area ■ Pedestrian Clear Zone



Parklet Permitting

All parklets are required to have permits from the Salt Lake City Transportation and Engineering Divisions, along with a Revocable Permit Agreement made with Salt Lake City Real Estate Services.

Construction Documents

In addition to the [required application materials](#), applicants for parklet dining areas must submit construction documents.

- Construction documents shall show:
 - * parklet location and context
 - * detailed site plan and elevations from all sides
 - * sections or cut-through drawings of the design
 - * construction details for assembly.
 - * Renderings and perspectives are optional.

Note: Final construction documents must be submitted to receive a permit.

Parklet Fees

- Following approval of the design, an invoice will be issued for the final permit. The permit fee is a one-time charge to cover the cost to the city of processing the permit application and removal of any parking spaces and meters.
- Permit fees depend on the processing and review time required for the application, the number of parking stalls occupied by the parklet, and if the parklet is located on a street with metered parking.

Pre- and Post-Installation Inspection

- A pre-installation, on-site inspection scheduled for at least 10 days before installation is required to authorize the beginning of construction.
- On-site construction and installation should be completed within 30 days.
- A post-installation, on-site inspection shall be scheduled within five days of the end of parklet construction, to verify that the parklet was built to plan.

Parklet Removal

- Parklets should be designed for winter removal in order to accommodate snow plowing and winter street maintenance (See [Section 14: Removal](#), for additional information).



Parklet Dining Area Guidelines

Parklets have additional requirements that differ from dining areas located on the sidewalk or in the park strip:

Season

- Parklets are permitted to operate from April 15th to October 30th each year.
- All materials associated with the parklet dining area shall be removed and stored on private property during the off-season (*October 31st to April 14th*).

Location

- Parklets are permissible on streets with speed limits of 25 mph or less.
- Parklets on streets with speed limits above 25 mph will be considered on a case-by-case basis.
- Shall be on streets with running slopes of no more than five percent, and cross slopes of no more than two percent.
- Shall be limited to the linear frontage of a building with direct, street level access to the dining area; this may be extended with the written permission of the adjacent property owner(s).
- Shall not be within 10 feet of a fire hydrant, or obstructing a manhole cover or utility access, in accordance with Salt Lake City Fire Code.
- Shall not be permitted in within 5 feet of a bus stop sign.
- In areas without marked parking stalls, the proposed parklet shall not create “orphaned” parking stalls of less than 22 feet in length.

Dimensions

- Parklets are typically limited to three adjacent parking stalls. Where parking stalls are not marked, one parking space is deemed to be 9 feet wide by 22 feet long.
- Exceptions to parklet dimensions will be considered on a case-by-case basis.
- Width is limited to a maximum of 8 feet.

Setbacks

- Parklets shall be located at least 18 feet away from street corners for visibility at street intersections.
- Where curb extensions exist (*bulb-outs*), parklet dining areas within the parking cut-out will be considered.
- Parallel parking spaces require 4-foot setbacks on either side to buffer the parklet from adjacent parking spaces.
- Perpendicular or diagonal spaces require 3-foot setbacks on either side.
- Adjacent to driveways, parklets shall provide a 2-foot setback from the outside edge of the driveway.

Platforms

- Parklets must be placed on elevated, load-bearing platforms flush with the curb (*typically 6 inches high at the curbside*).
- The platform shall be level, slip-resistant, and meet all relevant ADA accessibility standards.
- The gap between platform and curb shall not exceed ½ inch.
- The platform shall not interfere with curb drainage, or hinder access to utilities.
- Platforms must have wheel stops at each end, and stop signs on soft posts for directing traffic as needed.
- Visible, heavy barriers shall be installed on the traffic side of the platform.

Barriers

- Parklet barriers shall be anchored into platforms (*See Section 8: Barriers, for additional design requirements for barriers*). Parklet barrier arrangement should provide entrances that are easily accessible from both sidewalk directions (*See Section 6: Establishments Serving Alcohol, for more information*).

- Entrances to parklets shall be no less than three feet wide.

Lighting

- Consider lighting needs for nighttime use, and use pedestrian-scale lighting where needed.
- The use of solar-powered lighting is strongly recommended
(See [Section 12: Lighting](#), for details on the design and location of lighting).

Note: For additional design guidance, see these sections of [Salt Lake City's Parklet Pilot Program Design Guidelines](#): Footprint, Location, Functional Design, Engineering, Materials, and Safety.

Additional Information on Parklets:

For additional information on parklets see the [References section](#).

PARKLET EXAMPLE



PARKLET ON A SLOPE



Parklet images courtesy of San Francisco Planning Department



DESIGN GUIDELINES

26	PEDESTRIAN CLEAR ZONE	39	FURNITURE
32	FIRE HYDRANTS AND FIRE DEPT. CONNECTIONS	40	SOLAR ORIENTATION
33	PLATFORMS OR ELEVATED SURFACES	40	CANOPIES OR COVERS
33	ESTABLISHMENTS SERVING ALCOHOL	42	LIGHTING
33	ESTABLISHMENTS NOT SERVING ALCOHOL	42	SIDEWALK SURFACE
33	ENTRYWAYS	42	REMOVAL
33	BARRIERS	43	STORAGE
37	PLANTERS	43	CHANGE OF OWNERSHIP

1 Pedestrian Clear Zone

The pedestrian clear zone is the continuous, straight, unobstructed public sidewalk width dedicated to the path of travel.

There shall be no tables, chairs, barriers, planters, or streetscape elements in the pedestrian clear zone.

The pedestrian clear zone shall maintain a continuous, straight line, generally parallel to property lines, so that pedestrians do not need to weave around dining areas or streetscape elements in the sidewalk.

This promotes an accessible, equitable passageway for people of all abilities and mobility levels.

In this document, the term “pedestrian clear zone” is equivalent to “usable sidewalk space” as described in the [Salt Lake City Policy and Procedures Manual, Title 63-1-6: Criteria for Approval, A: Usable Sidewalk Space Required.](#)

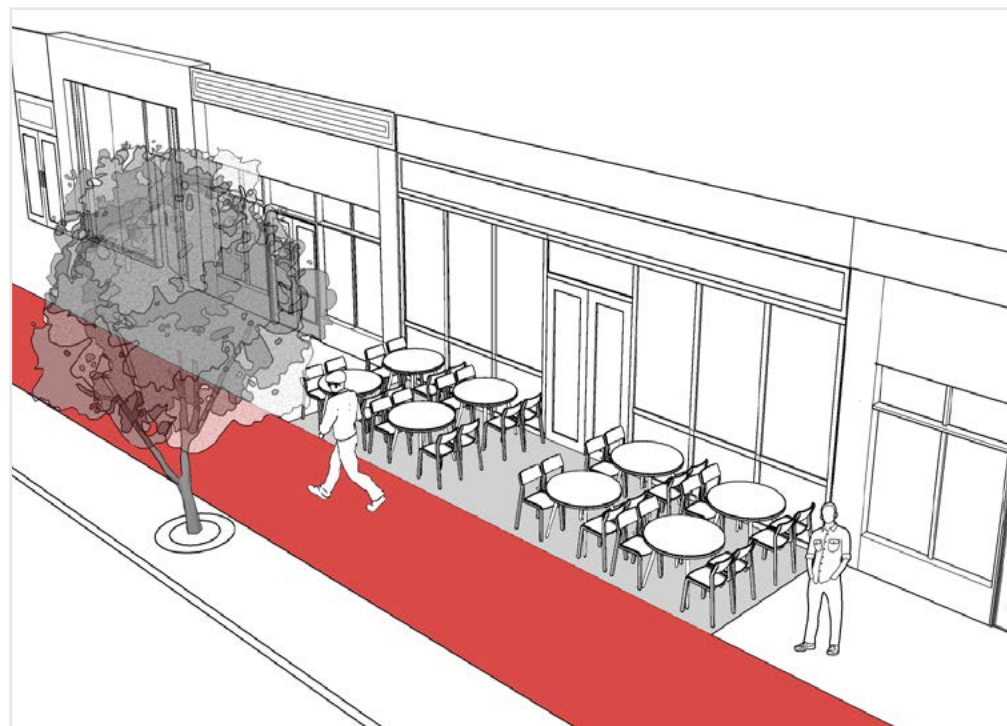

■ Pedestrian Clear Zone ■ Dining Area

1.1 Measurement of Pedestrian Clear Zone

FRONTAGE, SINGLE-TABLE, AND SIDE WALL DINING AREAS

The pedestrian clear zone shall be measured from the streetscape element closest to the building façade to the edge of the sidewalk dining area.

FIGURE 1.1 PEDESTRIAN CLEAR ZONE

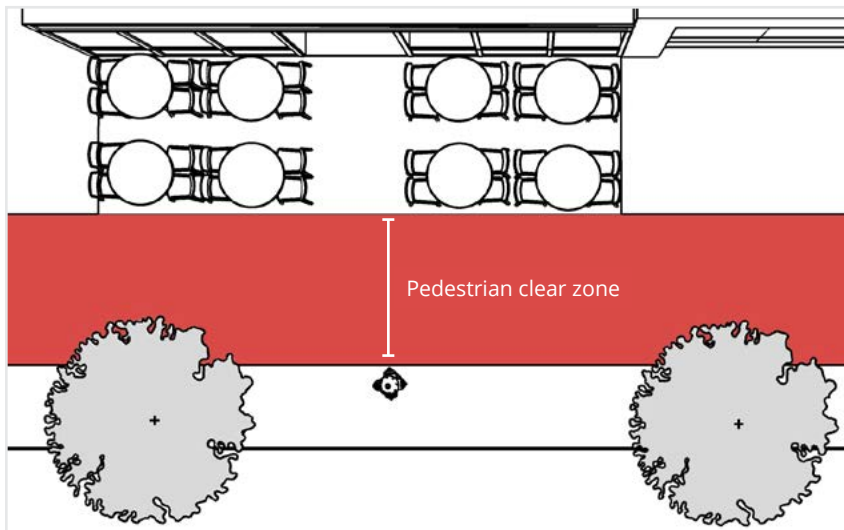

Streetscape Elements

Streetscape elements include, but are not limited to:

- * fire hydrants
- * trees & tree grates
- * manhole covers
- * bicycle racks
- * bollards
- * utility poles
- * mailboxes & newspaper boxes
- * benches
- * trash & recycling receptacles
- * utility boxes

CURBSIDE DINING AREAS

Pedestrian clear zone shall be measured from the building façade to the nearest streetscape element. Where no streetscape elements exist, the pedestrian clear zone may extend to the edge of the dining area.

FIGURE 1.2 PEDESTRIAN CLEAR ZONE FOR CURBSIDE DINING

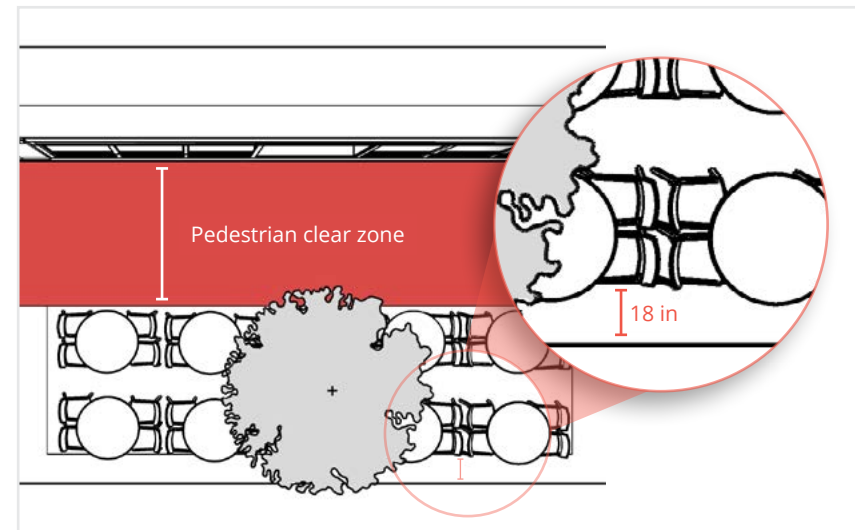

The street side of curbside dining areas shall be no less than 18" from the face of curb.

Design Guidelines

1.2 Distance of Pedestrian Clear Zone from Curb

Curb extensions (or *bulb outs*) shall not be included in measurements of pedestrian clear zone.

The pedestrian clear zone (see right) shall be measured from the streetscape element closest to the parallel building facade, regardless of the building frontage location of the sidewalk dining establishment.

Where no existing streetscape elements exist, the pedestrian clear zone measurement shall begin at 18" from the back of curb (See Figure 1.3).

1.3 Minimum Width of Pedestrian Clear Zone

Dining area encroachments shall maintain no less than 6 feet of pedestrian clear zone in most areas of Salt Lake City (See Figure 1.4).

Larger pedestrian clear zones are required in the Downtown Main Street Core Overlay District, the Central Business District, Sugar House Business District, and on State Street (See Figures 1.5 - 1.9).

FIGURE 1.3 AREA OF CURB FOR MEASUREMENT

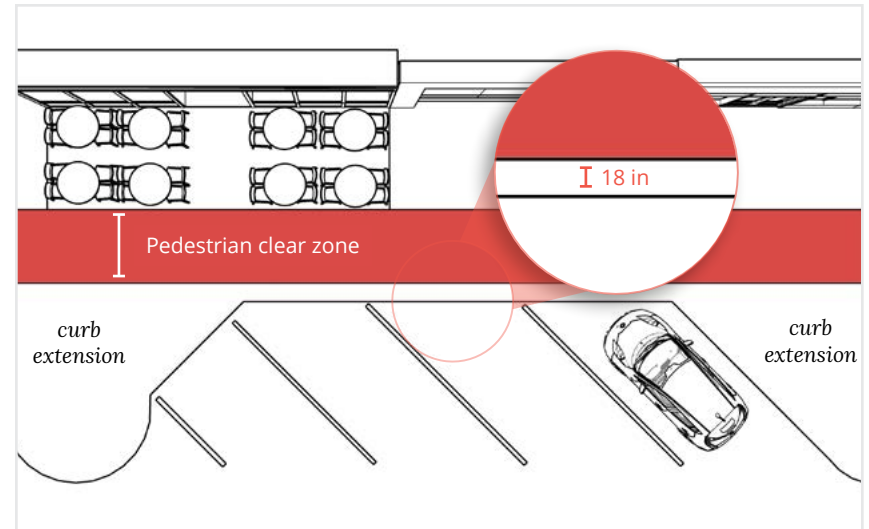

1.4 MINIMUM PEDESTRIAN CLEAR ZONE

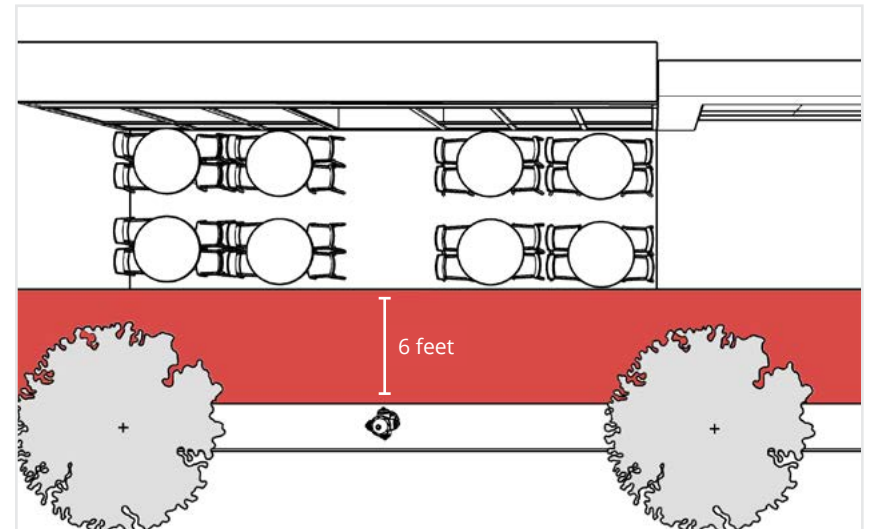

1.4 Minimum Width of Pedestrian Clear Zone in Downtown Main Street Core (DMSC) Overlay District.

The sidewalk dining area shall maintain no less than 10 feet of pedestrian clear zone in the Downtown Main Street Core Overlay District (As described in Chapter 21A.34.110 of the Salt Lake City Zoning Code).

On Main Street in the DMSC Overlay district, sidewalk dining areas where barriers are required, no portion of the barrier shall be bolted, anchored, or otherwise affixed the sidewalk or ground surface.

FIGURE 1.5 DOWNTOWN MAIN STREET CORE MINIMUM PEDESTRIAN CLEAR ZONE

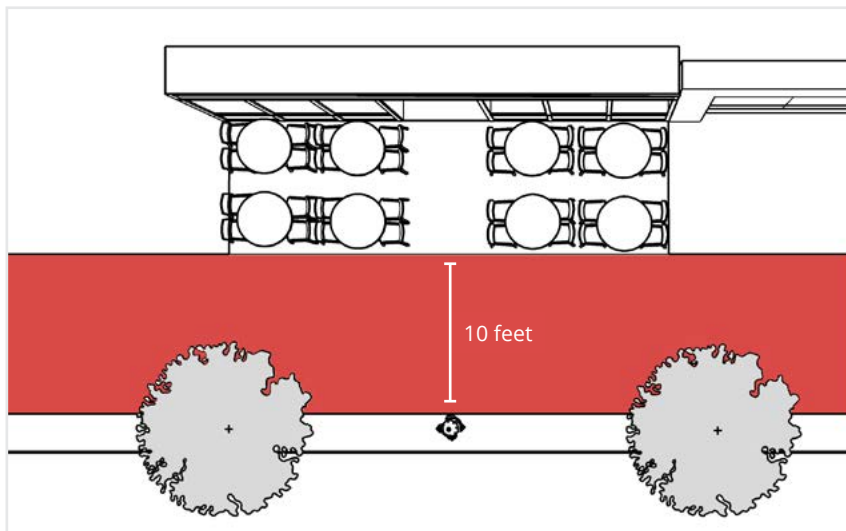
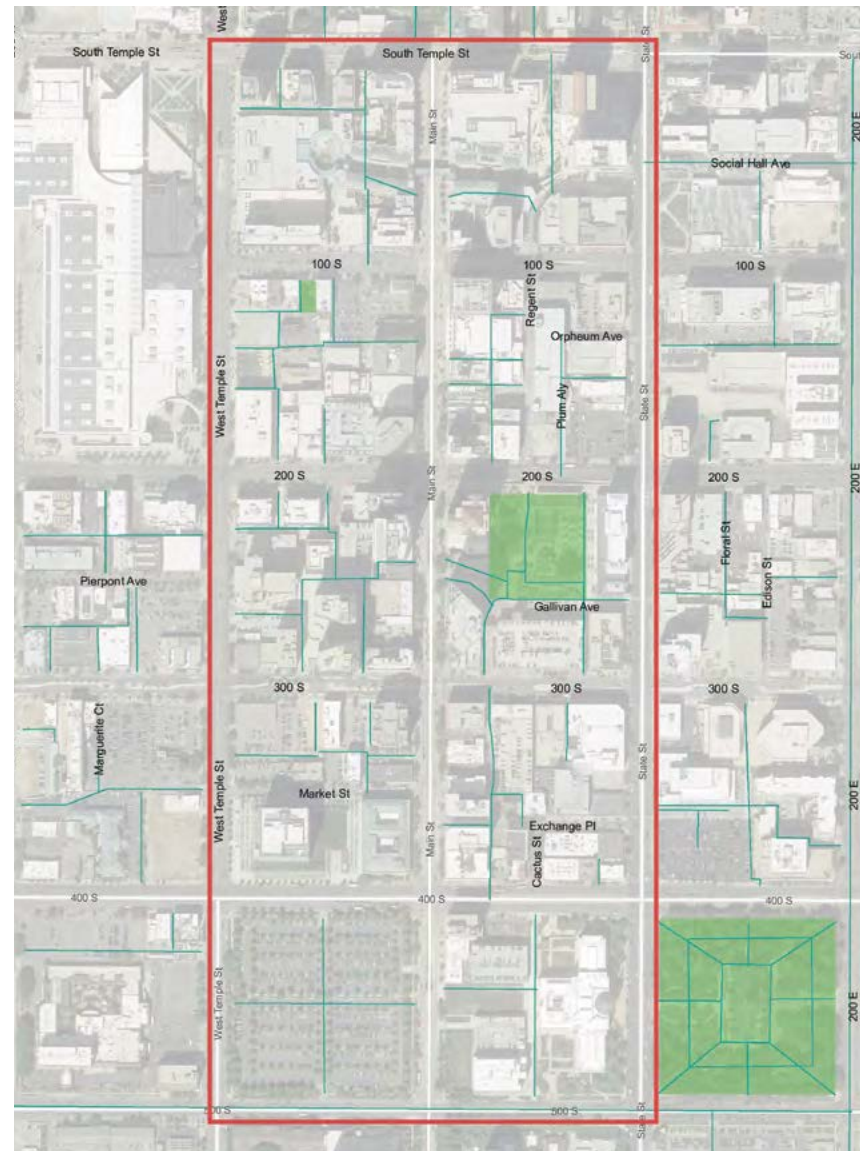

FIGURE 1.6 DOWNTOWN MAIN STREET CORE OVERLAY DISTRICT AREA



1.5 Minimum Width of Pedestrian Clear Zone in the Central Business District, Sugar House Business District, and State Street.

The dining area encroachment shall maintain no less than 8 feet of pedestrian clear zone in the Central Business District, the Sugar House Business District, and along State Street.

FIGURE 1.7 BUSINESS DISTRICT MINIMUM PEDESTRIAN CLEAR ZONE

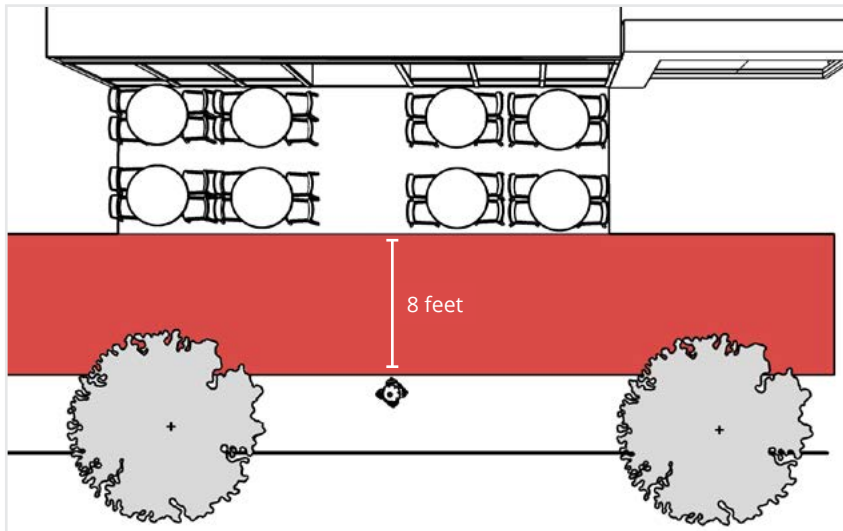

FIGURE 1.8 CENTRAL BUSINESS DISTRICT AREA

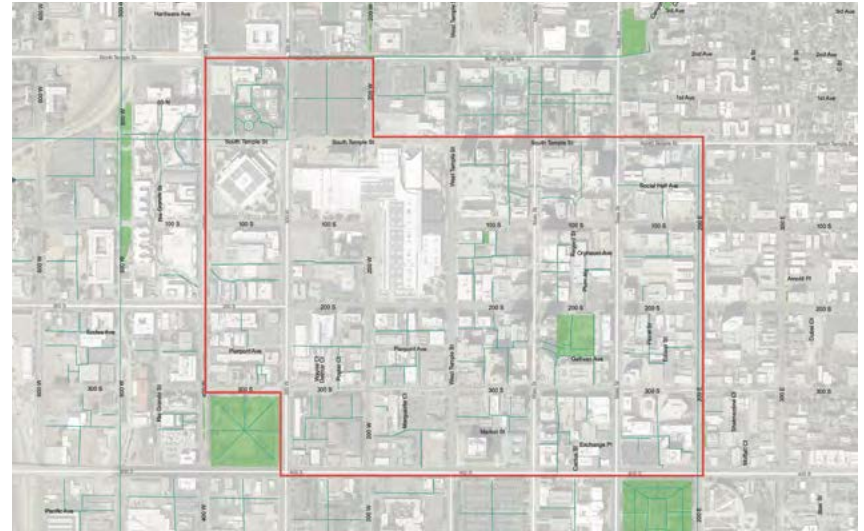
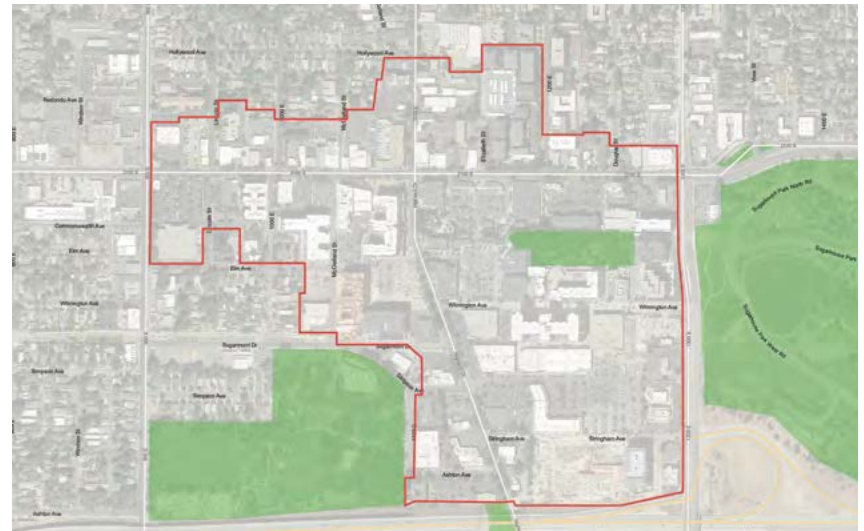

FIGURE 1.9 SUGAR HOUSE BUSINESS DISTRICT AREA



1.6 Accepted Encroachments in the Minimum Pedestrian Clear Zone Width

The Planning Division may modify the pedestrian clear zone requirement outside of the Main Street Retail Core and Business Districts to no less than five feet on sidewalks, provided two conditions are met:

- a 6-foot pedestrian clear zone would prevent operation of sidewalk dining; and
- a 5-foot pedestrian clear zone would not impair pedestrian priority and safety.

Note: *In residential areas, on sidewalks with a park strip, dining encroachments with 4 feet of pedestrian clear zone may be considered on a case-by-case basis.*

1.7 Narrow Sidewalks and New Buildings

Where compliance with these guidelines prevents the operation of sidewalk dining, or when new buildings are proposed, the Planning Division recommends creative ways to maximize indoor/outdoor threshold space on the applicant's property.

Accordion doors, bi-fold windows or doors, roll-up doors, insets to building facades where permitted by zoning code, and other approaches provide the experience of dining outdoors without physical encroachment into the sidewalk. (See figures 1.10 and 1.11, right, for examples).

In addition, Planning recommends that building design maximize visual transparency (*windows*) from sidewalk into establishments and vice versa, including lighting for optimal nighttime light spill and daytime solar shading to enhance the safety and quality of the pedestrian experience.

FIGURE 1.10 BIFOLD WINDOWS EXAMPLE



FIGURE 1.11 BIFOLD WINDOWS AND INSET SEATING AT CAMPOS COFFEE, SLC



1.8 Sight Distance Triangle

Sidewalk dining space located on corner lots or adjacent to driveways shall not obstruct the sight distance triangle (See “Sight Distance Triangle” in Chapter 21A.62 of the Salt Lake City Code and Salt Lake City Transportation Design Guides and Standards for additional information).

Note: Salt Lake City reserves the right to modify any sidewalk dining area in the public right-of-way to maintain a continuous pedestrian clear zone or sight distance triangle.

FIGURE 1.12 SIGHT DISTANCE TRIANGLE AREA

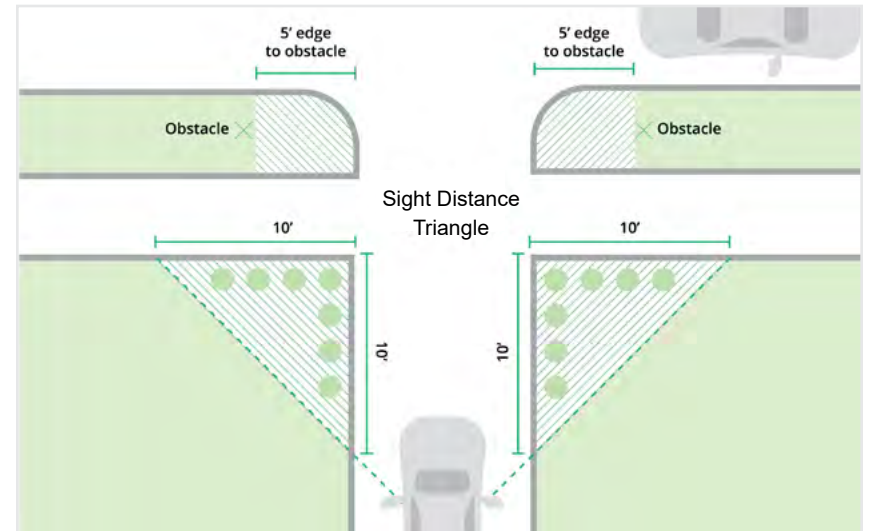

FIGURE 2.1 FIRE DEPARTMENT CONNECTION ON BUILDING

2 Fire Hydrants and Fire Dept. Connections

Sidewalk dining areas shall maintain 3 feet of clearance from fire hydrants and Fire Department Connections standpipes. For Fire Department Connections (FDC) located on buildings (see below), a 3-foot clear path from the street to the FDC shall be provided.

Tables and chairs may be placed in the clear path, but shall not be attached to each other nor affixed to the ground.



3 Platforms or Elevated Surfaces

No portion of the sidewalk dining area shall be raised in the style of a deck, platform, or other elevated surface, with two exceptions:

- where sidewalk slopes are greater than 1:20 and a platform is needed to meet accessibility requirements.
- In parklet dining areas, where platforms flush with the sidewalk surface are required.

Where platforms are allowed, barriers are required to be anchored into the platform. Barriers along the sidewalk are required to meet all design guidelines in [Section 7: Barriers](#) (except 7.1).

Note: Platforms must be removable to allow access during emergencies or maintenance activities. Concrete or other permanent application shall not be permitted. All platform materials are subject to the approval of Salt Lake City Corporation.

4 Establishments Serving Alcohol

The [Utah Department of Alcoholic Beverage Control \(DABC\)](#) requires that outdoor spaces where alcohol is served be “well defined, properly secured, and clearly delineated.”

As required by Utah statute, restaurants serving liquor shall contain distribution to the site. All Class C taverns and private clubs must control access of patrons through a point where identification may be checked.

To comply with State requirements, sidewalk dining areas for establishments serving alcohol shall:

- Clearly define the designated area with a sturdy, freestanding barrier.
- Have one clear entrance from the sidewalk, at least 36 inches wide, located in front of the egress doors.

5 Establishments Not Serving Alcohol

Establishments that do not serve alcohol are not required to use barriers of any type.

If definition of a sidewalk dining area is desired, Salt Lake City Planning encourages the use of planters (See [Section 9: Planters](#), for more details).

6 Entryways

All sidewalk dining areas shall have at least one entryway to/from the sidewalk.

Entryways to any sidewalk dining area (whether created by barriers or planters), shall have a minimum width of 36 inches for accessibility.

7 Barriers

Salt Lake City prefers sidewalk dining areas without barriers. In some instances, they may be suitable:

- When required to comply with Utah DABC requirements (see [Section 4: Establishments Serving Alcohol](#), at left, for details).
- Parklets shall use barriers on all sides adjacent to the street.
- Platforms, where required for Americans with Disabilities Act (ADA) compliance, shall use barriers.
- Locations that Salt Lake City Corporation determines need barriers to ensure the health, safety, and welfare of sidewalk users.

7.1 Freestanding Barriers

Salt Lake City prefers freestanding barriers. The use of freestanding barriers in the sidewalk minimizes damage to the public way, allows for freedom of movement for pedestrians, and facilitates rapid response for emergency services.

7.2 Barrier Requirements

- Barrier height shall be no less than 24 inches and no more than 36 inches.
- Barriers shall maintain ADA accessibility:
 - * The bottom of barriers shall not exceed 27 inches above the sidewalk (see [Figure 8.3](#), below).
 - * Chains or ropes shall have a minimum diameter of 1 inch.
- Barrier bases shall not create a tripping hazard.
- Bolting to a paving material other than concrete is not allowed.

FIGURE 7.1 PLANTERS USED AS FREESTANDING BARRIERS



7.3 Barrier Design

The guidelines in this section offer suggestions and considerations for sidewalk dining areas where barriers are used.

Figures 7.1 through 7.5 show acceptable barrier styles.

- Barriers may include (but are not limited to) planters, chains and posts, planter boxes, sectional fencing, or other freestanding fencing.
- Barriers should be sturdy, durable, and weather-resistant.
- Barriers should be sufficiently heavy to make movement or removal challenging.
- Barriers on casters or wheels should have brakes that do not protrude beyond the base of the barrier.
- Barrier edges should be tapered, with no sharp edges.
- Barrier materials or spacing should maintain a minimum of 50% transparency (*openness*) to provide visibility of street level activity; solid fencing is discouraged.
- Parklet-style dining areas should maintain 50% transparency (*openness*) along the sidewalk.
- All barriers should be of durable, high-quality materials such as finish-grade wood, metal, or sturdy recycled material.
- The use of reflective materials in sidewalk dining areas is discouraged.

Note: See [Figure 7.5](#) (opposite) and [Section 8: Planters](#), for more information regarding the use of planters as barriers.

FIGURE 7.2 FREESTANDING BARRIERS INTERSPERSED WITH PLANTERS



FIGURE 7.4 FREESTANDING BARRIER EXAMPLE



FIGURE 7.3 FREESTANDING BARRIERS WITH PLANTERS ATTACHED



FIGURE 7.5 PLANTERS LOCATED DEFINE SIDEWALK DINING AREA



Design Guidelines

7.4 Barrier Alignment

Barriers located next to the pedestrian clear zone should run in a straight line parallel to the building façade or curb line.

7.5 Prohibited Barriers

No fabric inserts, chain link fencing, chicken wire or cyclone fencing. Barriers shall be free of advertising unless authorized by Salt Lake City Zoning Ordinance (See Figure 7.6 for unacceptable barrier style).

7.6 Protrusions from Barriers

Barriers should be constructed so that they are free of objects that extend beyond the leased sidewalk area.

Examples of protruding objects include:

- hanging lights
- lanterns
- signs
- holiday/seasonal decorations
- large planter boxes
- banners

7.6 UNACCEPTABLE BARRIER EXAMPLE



8 Planters

Salt Lake City encourages the use of planters in sidewalk dining areas. Planters add color and texture to the streetscape, provide the benefit of greenery to patrons and passersby, and create visual and physical separation between the sidewalk dining area and the pedestrian passageway.

In addition to providing a public amenity along the sidewalk, planters are less likely to create the perception of a walled-off, segregated area than barriers or other types of fencing.

8.1 Freestanding Planters

Salt Lake City prefers freestanding planters. The use of freestanding planters in the sidewalk minimizes damage to the public way and allows greater freedom of movement for pedestrians with disabilities.

- Bolting to a paving material other than concrete is not allowed.

8.2 Planter Height

- Planter height should be no less than 2 feet and no more than 3 feet.
- The total height of planters with plants should be no less than 3 feet and no more than 5 feet measured from the ground surface (*see figure 8.1, right, for example*).
- Hedges should be maintained at a height of no more than 36 inches from the ground surface, and planter spacing should provide visibility into the dining area.

8.3 Visibility into Sidewalk Dining Area

Planter spacing should maintain a minimum of 50% transparency (*openness*) into the sidewalk dining area to provide visibility of street level activity.

Plants should provide a minimum of 50% visibility into the dining area, through the use of plants with an open form.

FIGURE 8.1 PLANTER AND PLANT HEIGHT MAXIMUMS

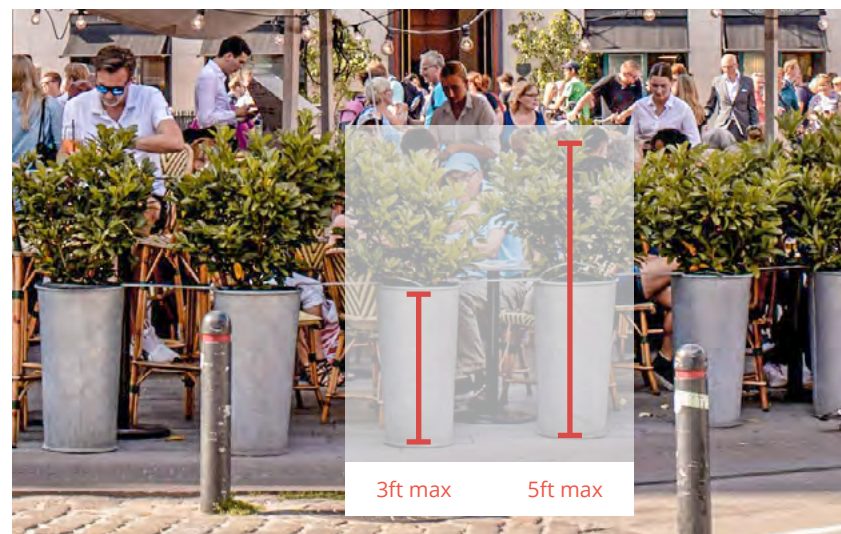

FIGURE 8.2 PLANTER SPACING WITH 50% TRANSPARENCY



Design Guidelines

8.4 Planter Alignment

Planters located next to the pedestrian clear zone should run in a straight line parallel to the building façade or curb line.

8.5 Maximum Height of Planter Base above Sidewalk Surface

The bottom of planters shall be 27 inches or less above the sidewalk surface, in order to maintain a cane-detectable pedestrian clear zone for visually impaired people.

8.6 Planter Materials

Planters should be commercial grade, and made of durable, high-quality materials such as finish-grade wood, metal, or sturdy recycled material.

FIGURE 8.3 MAXIMUM HEIGHT ABOVE SIDEWALK SURFACE



8.7 Protrusions from Planters

Planters should be constructed so that they are free of objects that protrude beyond the leased area. Examples of protruding objects include:

- string lights
- lanterns
- signs
- holiday decorations
- other objects

8.8 Plants

All planters should contain living plants that are consistently watered and maintained. Planters that contain non-living material should have at least 50% living plants.

Non-living material includes, but is not limited to:

- dead plants
- rocks
- bare soil
- bare mulch
- woodchips
- straw

For planters that remain outdoors in winter months, it is understood that plants may be dormant or absent from planters.

Note: Visual interest in the form of seasonal or holiday displays, evergreen plants, public art or other arrangement suitable for winter weather is encouraged.

8.9 Recommended Plant Characteristics

Given Salt Lake City's arid climate, the Planning Division recommends the use of urban-tolerant, heat-resistant plants. Plants with thorns or sharp leaves should be avoided.

- Water conservation recommendation: Establishment staff are encouraged to harvest any drinking water that remains after patrons have exited the establishment to use in watering plants.

9 Furniture

9.1 Furniture Material

All furniture should be made of durable, high-quality materials such as finish-grade wood, metal, or sturdy recycled material. The use of reflective materials in sidewalk dining areas is discouraged.

9.2 Freestanding Furniture

All furniture should be freestanding. Furniture should not be bolted, anchored, or otherwise affixed to any sidewalk, ground surface, building, tree, or posts for umbrellas or shade sails.

- “High” or “bar stool” height tables and chairs that are not ADA-compliant shall not be permitted.
- Furniture should not be secured to trees, lampposts, street signs, hydrants, etc. by means of ropes, chains or any other such devices at any time.

9.3 Waste/Recycling Receptacles

Establishments that do not provide wait service should provide customers with a bussing station with compartments for waste, recycling, and tableware.

9.4 Tables

Sidewalk dining areas without barriers should provide tables of sufficient weight that they cannot be easily shifted by patrons or pedestrians.

Preventing movement of furniture into the pedestrian clear zone helps maintain an equitable passageway for people of all ranges of mobility.

Note: When guidelines use the word *shall*, the city requires it to be followed. Requirements are made to comply with other agency regulations (such as ADA access or DABC rules), to ensure the health, safety, and welfare of the general public, or to implement City goals.

9.5 Accessible Tables

To ensure that outdoor dining can be enjoyed by all patrons, consider providing tables that are ADA accessible. These accessibility requirements are recommended for universally accessible outdoor dining:

- At least 20% of tables in the sidewalk dining area, but no less than 1 table, should maintain accessibility.
- Tabletop surfaces should be between 28 and 34 inches above the sidewalk dining area surface.
- Knee clearance under the tabletop should be 27 inches high for a depth of at least 8 inches.
- Foot clearance should be at least 9 inches high for a depth of no less than 11 inches.
- Clear sidewalk space (*floor space*) at the table should be at least 30 inches wide and 48 inches deep.
- Where possible, accessible seating should be located where the sidewalk has a slope that is no greater than 1:50.

10 Solar Orientation

During the summer months, south- and west-facing sidewalk dining areas may become uncomfortably hot during daylight hours, but will likely be more pleasant for outdoor dining in early spring and fall.

Outdoor dining without shade can be uncomfortable during the heat of the summer. Operators may consider how to provide shade over their outdoor dining using umbrellas, shade sails, or awnings.

11 Canopies or Covers

11.1 Umbrellas

Salt Lake City encourages the use of durable, high-quality umbrellas, in all sidewalk dining areas during summer months. Market umbrellas, designed specifically for commercial use, are preferred.

11.2 Shade Sails

Shade sails shall be permitted, and should be anchored to a building and/or a maximum of three posts. Posts and sails should conform to ASTM International standards; applicant should provide specification sheet.

No portion of the post or shade sail should be bolted, anchored, or otherwise affixed to any City property (*for example, sidewalk, street, ground surface, tree, planter, or other street furniture*).

Note: *Shade sails should stay within the leased sidewalk dining area.*

11.3 Awnings

Awnings shall be permitted.

FIGURE 11.1 ACCEPTABLE UMBRELLA EXAMPLE



FIGURE 11.2 ACCEPTABLE SHADE SAIL EXAMPLE



11.4 Minimum Height of Umbrellas, Shade sails, or Awnings

All overhead portions of umbrellas, shade sails, and awnings should measure no less than 7 feet above the sidewalk.

11.5 Maximum Height of Umbrellas, Shade Sails, or Awnings

Umbrellas, shade sails, and awnings should not exceed 12 feet in height to avoid obstructing neighboring businesses.

11.6 Umbrellas or Shade Sail Material

Umbrellas, shade sails, and awnings should be made of durable, weather-resistant fabric. Fabrics that are heat-absorbing, highly reflective, or non-recyclable are discouraged.

Note: Umbrellas and shade sails shall be free of advertising unless authorized by Salt Lake City Zoning Ordinance.

11.7 Protrusions from Umbrellas, Shade Sails, and Awnings

Umbrellas, shade sails, and awnings should be constructed to be free of objects that protrude beyond the leased sidewalk dining area.

11.8 Removability of Umbrellas and Shade Sails

All types of umbrellas and shade sails should be temporary and removable.

Avoid excessively large posts, posts that appear structure-like, or that create an obstruction in the sidewalk.

11.9 Other Canopies or Coverings

Canopies or coverings for sidewalk dining areas (other than umbrellas, shade sails, and awnings), are not allowed.

Other Coverings

Other coverings include, but are not limited to:

- * pergolas
- * trellises
- * arbors
- * bowers
- * pavilions
- * screens
- * lattices
- * any structure that suggests a roof and/or walls
- * other open or closed structures

FIGURE 11.3 UNACCEPTABLE COVERING EXAMPLE



12 Lighting

For establishments open during nighttime hours, hanging lanterns, festoon lights, string lights, or other small, pedestrian-scale lighting are acceptable.

Lighting should not be bolted, anchored, or otherwise affixed to any sidewalk, ground surface, tree, streetlight, or other City property.

All lighting, wires, and other related accessories shall be rated for outdoor use and should not protrude beyond the leased outdoor dining area. Light bulbs should be energy efficient.

All power shall be supplied by the establishment. Power from any City-owned source shall not be used.

Sidewalk dining area lighting should be located, directed, or designed in such a manner so as not to create light pollution or glare on adjacent properties.

Sidewalk dining lights should be turned off at 11 p.m.

Note: Salt Lake City is unable to turn off street lighting adjacent to sidewalk dining areas; please take this into consideration when planning for any additional lighting.

13 Sidewalk Surface

The establishment is responsible for the maintenance of the sidewalk or ground surface within the dining area.

To ensure wheelchair accessibility and prevent tripping hazards, no surface treatment shall be applied to the sidewalk surface, including but not limited to:

- artificial turf
- carpet
- paint or stain
- tile
- special pavers
- other surface treatments

FIGURE 12.1 ACCEPTABLE LIGHTING EXAMPLE



14 Removal

There may be some instances in which sidewalk dining areas require removal at the request of Salt Lake City.

14.1 Public Safety Emergencies

There may be occasions where a dining area will need to be removed with little notice. Fire, police, and/or ambulance services may need to respond quickly to life-safety events.

Because sidewalk dining areas may be located above underground utilities, in the unlikely event of a utility failure threatening public safety (such as a gas or water leak), the City may remove the dining area furnishings with little or no notice.

Note: The City is not responsible for the cost or repair of any damage to the dining area furnishings.

14.2 Regular Utility Maintenance

Salt Lake City Public Utilities often needs to access underground infrastructure in or adjacent to sidewalk dining areas, such as manholes, cleanouts, meters, and storm drains. Salt Lake City endeavors to provide as much notice as possible for all maintenance activities.

14.3 Special Events

The City may require removal of the dining area during large public events held in the right-of-way, such as parades or street festivals.

The City, or the event sponsor, will endeavor to notify you as early as possible of the dates and duration that your sidewalk dining area will need to be removed.

14.4 Streetscape Improvements

The City may require removal of the dining area to install streetscape improvements, such as repaving, new transit stop installation, tree planting, utility main or other public infrastructure improvements.

The City will endeavor to notify you as early as possible that your sidewalk dining area will require removal. Circumstances permitting, you may be able to re-install your sidewalk dining area after streetscape improvements are complete.

For greater detail on the City's authority to alter, modify, or relocate sidewalk dining areas, see Title 14 of Salt Lake City Code: Streets, Sidewalks, and Public Places, in particular [Chapter 14.32.125: Relocation of Structures in Public Way](#).

Note: When removal is required, permit holders may need to store all furnishings and equipment off-site, on private property.

Establishment operator is responsible for the costs of storing and re-installing the dining area materials.

15 Storage

The Planning Division encourages winter storage of all sidewalk dining components off-site, for ease of snow removal and pedestrian accessibility during inclement weather.

Where feasible, sidewalk dining furniture and materials should not be stored in the public right-of-way.

16 Change of Ownership

When the management of the establishment changes, the new owner shall either remove the sidewalk dining area or transfer to permit to themselves.

The new management is required to contact Real Estate Services to transfer the permit.

Glossary

Certificate of Appropriateness:

A document issued by the Planning Division allowing an applicant or owner to proceed with work that affects the exterior appearance of a property in locally-designated historic district or on property listed in the Salt Lake City Register of Cultural Resources, following a determination of the proposal's suitability according to applicable criteria.

Curb Extension (also called bulb-out):

Extend the sidewalk into the parking lane and reduce the distance between curbs at crosswalks. Curb extensions lessen pedestrian street crossing time, visually and physically reduce street width, and enhance the ability of pedestrians and drivers to see each other at crosswalks.

Park Strip:

The landscape area within a public way located between the back of street curb and the sidewalk, or in the absence of a sidewalk, the right-of-way line.

Pedestrian Clear Zone:

The continuous, straight, unobstructed public sidewalk width dedicated to the path of travel (See *Section 1: Pedestrian Clear Zone*, for details). The term “pedestrian clear zone” used in these design guidelines is equivalent to “usable sidewalk space” as defined in *Salt Lake City Policy and Procedures Manual, Title 63-1-6: Criteria for Approval, A: Usable Sidewalk Space Required*.

Sidewalk Dining Area:

An outdoor area located within the public right-of-way (ROW) which is operated and maintained by an establishment that serves food and/or beverages, such as coffeehouses, tea shops, bars, or restaurants.

Sight Distance Triangle:

A triangular area formed by a diagonal line connecting two (2) points. The purpose of the sight distance triangle is to define an area in which vision obstructions are prohibited. (See definition in *Chapter 21A.62.040* and illustration in *Chapter 21A.62.050 of the Salt Lake City Code* for additional details).

Parklet Information

Best Practices for Implementing and Designing Parklets

Reclaiming the Right-of-Way

https://nacto.org/docs/usdg/reclaiming_the_right_of_way_brozen.pdf

Parklets: Tiny Parks with Big Impacts for City Streets

https://nacto.org/wp-content/uploads/2015/04/parklets_tiny_parks_with_big_impacts_for_city_streets_gould.pdf

Parklets Permits

All parklets are required to have permits from the Salt Lake City Transportation and Engineering Divisions, in addition to a Revocable Permit Agreement made with Salt Lake City Real Estate Services.

mystreet@slcgov.com

<https://www.slc.gov/mystreet/permits/>

References

Salt Lake City Zoning Lookup Map

<https://maps.slcgov.com/mws/zoning.htm>

Salt Lake City Real Estate Services

<https://www.slc.gov/can/real-estate-services/>

Central Business District

The Central Business District may change over time. For the most current boundaries, contact the [Salt Lake City Department of Public Services](mailto:publicservicesinfo@slcgov.com) at publicservicesinfo@slcgov.com.

Downtown Main Street Core Overlay District

https://codelibrary.amlegal.com/codes/saltlakecityut/latest/saltlakecity_ut/0-0-0-67057#JD_21A.34.110

Park Strip Landscaping Standards

https://codelibrary.amlegal.com/codes/saltlakecityut/latest/saltlakecity_ut/0-0-0-70325#JD_21A.48.060

Salt Lake City's Urban Forestry Division

<https://www.slc.gov/parks/urban-forestry/>

Sight Distance Triangle Standards

https://codelibrary.amlegal.com/codes/saltlakecityut/latest/saltlakecity_ut/0-0-0-72045#JD_21A.62.040

Sugar House Business District

<https://maps.slcgov.com/mws/zoning.htm> (CSHBD1 and CSHBD2)

Utah Department of Alcoholic Beverage Control

<https://abc.utah.gov/>

Questions? Contact Us

Call Real Estate Services or visit the permit office at the Salt Lake City and County Building:

451 South State Street - Room 215.

Salt Lake City, UT 84114

(Located between 400 and 500 South and between State Street and 200 East)

Real Estate Services	real_estate@slcgov.com 801.535.6230
Zoning	zoning@slcgov.com 801.535.7700
Engineering	engineeringinfo@slcgov.com 801.535.7961
Public Utilities	PUDevServ@slcgov.com 801.483.6900
Transportation	slc.transplan@slcgov.com 801.535.6630
Urban Forestry <i>(for park strip trees)</i>	urbanforestry@slcgov.com 801.535.7800



Department of Community and Neighborhoods

Real Estate Services Division

451 South State Street - Room 425

P.O. Box 145460

Salt Lake City, UT 84114 - 5460
